

STANDARD DRIVEWAY DETAILS

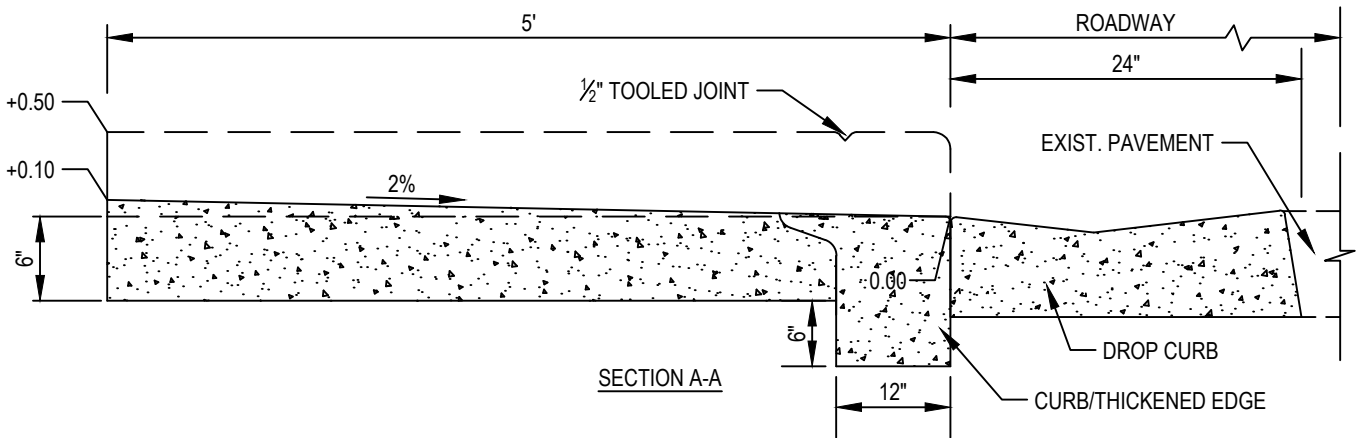
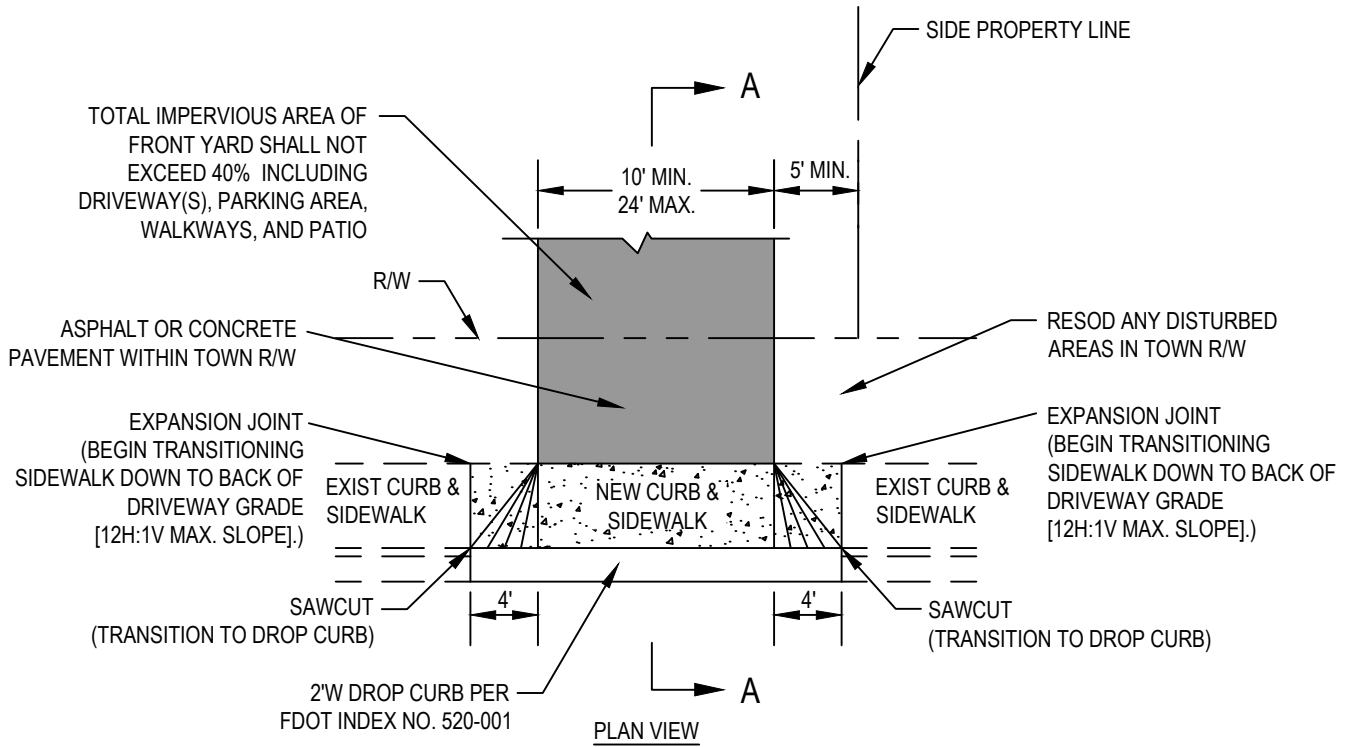

DRIVEWAY CONNECTION TO CURB/GUTTER ROADWAY

MINIMUM PAVEMENT SPECIFICATION IN TOWN R/W

MATERIAL	SURFACE	BASE COURSE	SUBGRADE
CONCRETE:	6" THICK (3,000 PSI) MIN.	N/A	12" THICK @ 98% AASHTO T-180
ASPHALT:	1.5" THICK SP-9.5 OR S-III	6" THICK (LBR100) @ 98% AASHTO T-180	12" THICK @ 98% AASHTO T-180



TOWN OF HAVERHILL
ENGINEERING STANDARDS

RESIDENTIAL DRIVEWAY: CURB /GUTTER

DETAIL NO.

01

ISSUED: 06/05/2024